

# LABTOP INTEGRATED PUMP SYSTEM



When it counts,  
count on Unibloc®.

- Compact, highly mobile, complete pumping solution
- Innovative design
- Stainless-steel quality construction
- Maintain pressures up to 90 PSIG

# A SIMPLE BUT COMPLETE SOLUTION

**Professionals in the biotechnology and pharmaceutical industries face unique challenges relating to cleanability, shear sensitive transfers scalability and pilot applications that other types of manufacturing don't require.**

What's more, many professionals require a product that is mobile and self-sustainable, without needing other pieces of equipment to complete a processing task. With LABTOP, Unibloc has developed a pumping solution to address these issues.

**LABTOP®** is Unibloc's engineered solution for the biotechnology and pharmaceutical industries. Its "plug-and-go" design is simple and efficient, it can handle small volumes, and you can easily scale it up based on your needs. That's why the LABTOP Series has been a top-selling complete pumping solution for more than 20 years.

## **Compact, Mobile and Efficient**

LABTOP features a compact and highly mobile design perfect for filtration, chromatography, pilot applications, R&D and more. LABTOP makes your pumping activities simple and efficient. Each LABTOP is composed of a Unibloc pump, a motor and controller enclosed in a stainless-steel canopy, with bidirectional flow for versatility. Unibloc offers three versions of the LABTOP: the 200 Series, the 300 Series and the 400 Series.



Filtration (Units or) Systems

## **HIGH QUALITY, HIGHER PRESSURES**

Unibloc's LABTOP series is capable of generating higher pressures than, for example, peristaltic pumps, commonly sold by our competitors. In addition, our lobe pump technology featuring all stainless-steel construction is the highest quality in the industry and designed to last a lifetime of use.



# PLUG AND GO

## 300 AND 400 SERIES FEATURES AND BENEFITS

- All stainless-steel construction
- Plug-in-the-wall unit for 1x110VAC or 1x220VAC (300 Series) or 3x220VAC (400 Series) input
- Maintain pressures up to 90 PSIG
- Bidirectional flow
- All materials are FDA/USP Class VI compliant
- Each unit performance tested and documented
- Full MTR documentation available upon request
- Hastelloy-C and low-ferrite SS pumps available
- Front cover drain available for full drainability
- High-grade polish and electropolish available



## 200 SERIES FEATURES AND BENEFITS

- Touch screen interface
- All stainless-steel construction
- Plug-in-the-wall unit for 1x110VAC or 1x220VAC
- Maintain pressures up to 90 PSIG
- Compact design
- High-grade polish and electropolish available
- Bidirectional flow
- All materials FDA/USP Class VI compliant
- Vertical mounting for full drainability
- Each unit performance tested and documented
- Full MTR documentation available upon request
- Hastelloy-C and low ferrite SS pumps available

## 200 SERIES LABTOP

Dimensions				Specifications			
MODEL	A in (mm)	B in (mm)	Weight lbs (kg)	Pump Size	Max Capacity GPM (KPM)	Port Size in (mm)	RPM MAX
200-0	16.7 (425)	2.8 (70)	78 (35)	PD200-0	3 (11.4)	0.375 (10)	1200
200	17.1 (435)	3 (76)	78 (35)	PD200	8 (30.4)	0.5 or 0.75 (13 or 19)	1200
250	17.5 (443)	3.2 (82)	79 (36)	PD250	11 (41.8)	0.750 (19)	1200
275	17.8 (452)	3.4 (85)	80 (37)	PD275	14 (53.2)	0.75 or 1.0 (19 or 25)	1200

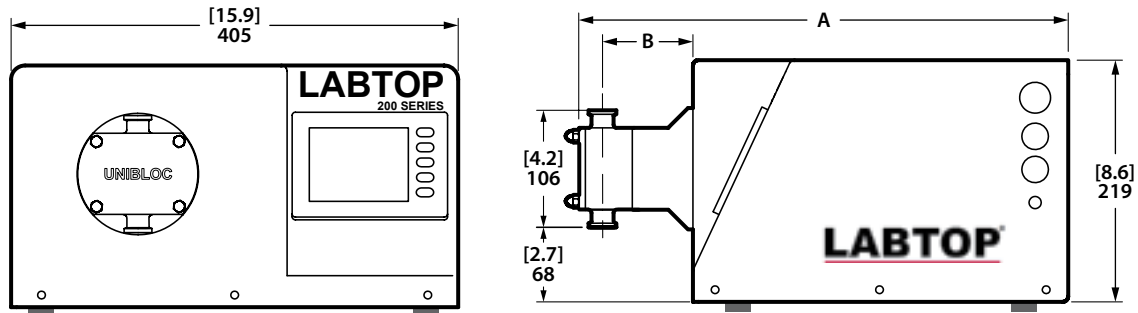

## 300 AND 400 SERIES LABTOP

Dimensions							
MODEL	A in (mm)	B in (mm)	C in (mm)	D in (mm)	E in (mm)	F in (mm)	Weight lbs (kg)
300	11.4 (290)	18.5 (469)	18.8 (477)	5.7 (144)	4.8 (123)	2.0 (52)	99 (45)
350	11.4 (290)	19.3 (491)	18.8 (477)	5.7 (144)	4.8 (123)	2.3 (58)	103 (47)
400	13.4 (340)	25.3 (643)	28.9 (733)	7.6 (192)	6.5 (164)	1.5 (39)	257 (117)
450	13.4 (340)	25.9 (657)	28.9 (733)	7.6 (192)	6.5 (164)	1.8 (45)	301 (137)

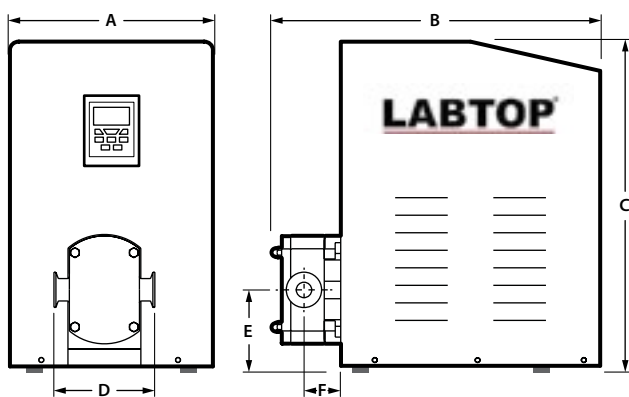

Specifications			
Pump Size	Max Capacity GPM (KPM)	Port Size in (mm)	RPM MAX
PD300	12.6 (47.9)	1.000 (25)	450
PD350	18.0 (68.4)	1.5 or 2.0 (38 or 51)	450
PD400	40.5 (153.9)	1.500 (38)	500
PD450	54.5	2.000	500

Unibloc Hygienic Technologies provides a broad portfolio of powerful solutions for companies around the world.