

Atlas Copco



The complete Wellpoint dewatering solutions

The WEL range

PolyPump Ltd

Providing your pumping solutions
sales@polypump.co.uk
01296 488 294

Wellpoint pumps

The **WEL range** of fully automatic, rapid self-priming pumps is designed for wellpoint applications with a high flow rate. The **WEL PST** model, a high-performance unit, is suitable for heavy applications where it needs to work 24 hours per day, with a highly efficient design that guarantees fuel savings.

The **WEL ECO** is capable of drawing significant quantities of air and maintaining a wellpoint system under vacuum, or draining an excavation, thanks to the semi-open impeller, which also makes it suitable for pumping liquids with solids in suspension.

The automatic **WEL TANK** range is suitable for applications with changing ground water level and flow requirements. Being electric driven, it is very silent, energy efficient and suitable to work in residential areas.



MAX. FLOW
UP TO **340** m³/h



+25% MORE
EFFICIENT
IN DEEP
WATER



MAX. HEAD UP
TO **32** m



INCREASED
UTILIZATION
Simple service and
long service
intervals



ENGINEERED
DESIGN
for severe
conditions



30% FUEL
SAVINGS



STACKABILITY
one by one



15% SPACE
SAVING



COMPACT
SIZE
with maximum flow



Wellpoint applications

The **WEL range** is the most efficient system for pumping groundwater where air is present and being able to manage large field areas. The groundwater pick level is dynamically balanced to guarantee construction operations.

1. Dewatering in construction

A wellpoint system of dewatering is regularly used when the groundwater level is close to the surface and the pump must handle a high percentage of air within the water that is drawn in from the ground material. It is the best choice for ground level reduction and it is used mostly before excavation for footings. Skyscrapers, underground railways, roads ... there are many applications.



3. Polluted soil remediation

During sanitation works, a number of preparatory operations are required, including pipeline dewatering and drying, and removal of the groundwater to assure the terrain.



2. Pipeline on shore – oil and gas

Pipelines used to transport crude oil or natural gas must be dewatered to guarantee the quality of the hydrocarbons, prevent the formation of hydrates and protect the pipe from internal corrosion.



4. Tunneling (flood control)

Groundwater is often an issue for tunneling, and dewatering is needed to allow excavation. In this case, a wellpoint system is the best choice to prevent consistent water leakage into the site. These pumps can control the groundwater level and handle both air and water.



WEL PST

The **WEL** piston pump core is designed to perform in severe conditions, with high water flow and with air present in the wellpoint; it can be applied anywhere.

GREAT PERFORMANCE

- The automatic self-priming pump is the key to this unit. No extra vacuum assistance is needed.
- Dry running system helps avoid downtime.

GALVANISED STONE CATCHER

- Stone catcher traps solids in suspense, in case of inappropriate machine use.
- Stainless steel removable filter handling up-to 8 mm solids handling.
- Easy clean up and maintenance.
- Easy flushing with clean water.

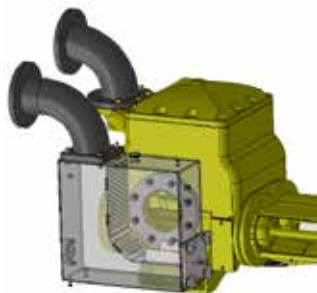

TOTAL ACCESS FOR MAINTENANCE

- Front door enables easy access to clean up cylinders' chamber and allow for easy replacement.
- Canopy version enables total access for the right maintenance.

**2000h
SERVICE
INTERVAL**



**EASY
MAINTENANCE
AND CLEAN-UP**

FUEL EFFICIENCY

- Very low fuel consumption.



120 RUNNING
HOURS
BEFORE
REFUELING



*Available as an option



SAVE SPACE

- Stackability is key to storing the units and saving space.
- Simple belt tensioning to guarantee correct coupling between pump and engine.



WATER DRAINAGE SYSTEM

- Double tank to avoid spillage.
- Easy-release valve system to flush the water after every engine start.



WEL ECO

WEL ECO is the high-performance wellpoint range. Sizes 4 to 6 are commonly used in very long pipeline wellpoint applications.

PRIME YOUR PUMP WITH A CONTINUOUS MIX OF AIR AND WATER

- Patented Air System separator, robustly designed and engineered, to manage consistent mixed water.
- A mechanical trap system avoids moisture in the vacuum pump on every start-up.
- Release valve enables simple pipeline disassembly in all conditions.

MINIMIZE CLEANING TIME

- Simple and quick access to the wear components.

**EASY
MAINTENANCE**
 **3 MIN
CLEAN-UP**

WORK IN THE TOUGHEST CONDITIONS

- Performance tested and verified in the toughest working conditions.
- Robustness in prime and reprime





REFUEL ONCE IN A WORKING WEEK

- Very low fuel consumption.



50 HOURS RUNNING BEFORE REFUELING

SOLIDS HANDLING CAPABILITY

- The whole range can handle high solids.

UP TO 76 mm SOLIDS



ONE PUMP MULTIPLE PACKAGING

- The WEL ECO pump range is based on modular designs with mobility, heavy duty skid and stack frame options available



* Optional on some models



WEL tank

The **WEL tank** is an electric driven pump system, totally automatic, used to manage wellpoint fields where the flow and the ground level of water is continuously changing.

The equipment is capable to adapt the performance of flow according to the different type of ground and conditions.

The **WEL Tank** is really suitable to work in residential areas, waste water treatments and polluted soil remediations, thanks to operate in energy saving conditions.

ENERGY SAVING

- The WEL tank design is based on an automatic system to provide different type of flow according to the field test and environment.

AUTOMATIC SYSTEM



VARIABLE FLOW
UP TO 274 m³/h



MAX. POWER CONSUMPTION
15 kW

CLEAN-UP THE TANK
3 min

MAX. HEAD UP TO 24 m

HIGH 90% EFFICIENCY

FLEXIBLE FIELD INSTALLATION

PolyPump Ltd

Providing your pumping solutions

sales@polypump.co.uk
01296 488 294

FLEXIBLE FIELD INSTALLATION

- Thanks to the port predisposition that allow to connect all the pipeline according to the orientation of the unit.

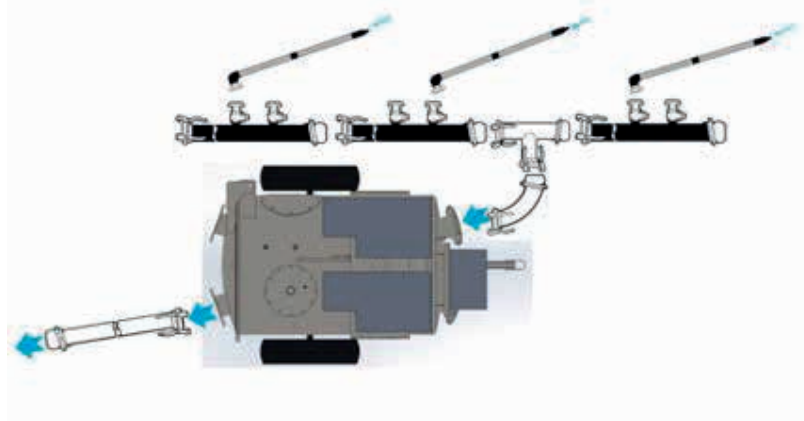

SERVICEABILITY

- The unit, with the hinge door can be opened to guarantee cleaning or replacement pumps & wear components directly in field with any lifting devices.



CONTROL PANEL

- Vanguard of our automatic dry priming allows to use the right power for Low Medium Maximum Flow.
- It act on 2 submersible and 2 vacuum pump in start up switch on switch off .



WEL

Technical data



stageV



stageV



| Specifications | | WEL PST 100 | WEL ECO 4-250 | WEL ECO 6 | WEL ECO 6-250 | WEL Tank |
|------------------------------|-------------------|-------------|---------------|------------|---------------|------------------|
| Max. head | m | 20 | 32 | 26 | 28 | 24 |
| Max. capacity | m ³ /h | 100 | 180 | 300 | 340 | 137+137 (274) |
| Nominal Air capacity | m ³ /h | - | 75 | 75 | 75 | 105+105 (210) |
| Suction / discharge size | in | 6 | 4 | 6 | 6 | 4 or 6 |
| Max. solids handling | mm | - | 50 | 50 | 76 | - |
| Best efficiency point | % | 93 | 65 | 65 | 62 | 90 |
| Max. absorbed power | kW | 5,5 | 13,2 | 14 | 19 | 5,6 + 5.6 (11.2) |
| Version | | Canopy | Open frame | Open frame | Open frame | Open frame |
| Engine | | | | | | electric driven |
| Engine Emission | EU | Stage 5 | Stage 5 | Stage 5 | Stage 5 | - |
| | LRC | T3 | T2-T3 | - | T2-T3 | - |
| Max. operating speed | rpm | 2000 | 1800 | 1800 | 1800 | 1450 (50Hz) |
| Max. fuel autonomy | h | 120 | 53 | 53 | 53 | - |
| Weight and dimensions | | | | | | |
| Weight | kg | 1590 | 960 | 1060 | 1060 | 900 |
| Width | mm | 1100 | 995 | 995 | 995 | 1370 |
| Length | mm | 2200 | 1950 | 2115 | 2115 | 1900 |
| Height | mm | 1550 | 1520 | 1520 | 1520 | 1850 |

Operation area

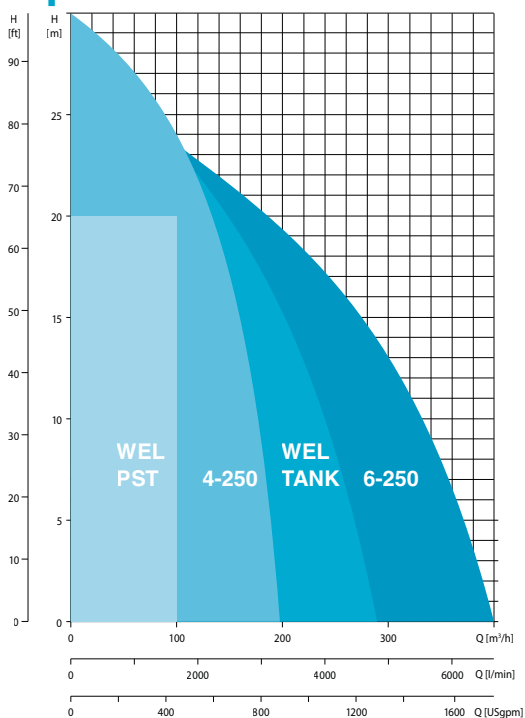

LOOKING FOR ELECTRIC?*

E-Pump OPTIONS
ALSO AVAILABLE



* Please consult with your local representative.

Wellpoint accessories

Complete wellpoint solutions available

Wellpoint spear

Filters that are installed in ground and act as water intake. Available in multiple materials options suitable for any environment.



| Length | Connections | | Material |
|---------|-------------|----------|--|
| 0,35 mm | 32 mm | 1 1/4 in | PVC + PE HD/Aluminium +Stainless steel |
| 0,65 mm | | | |

Pipe connections / joints

Wide variety of connections and joints in different sizes for easy and quick connections.



| Type | Connections | | Material |
|----------|--------------------|--------------|------------------|
| Threaded | 100 - 120 - 150 mm | 4 - 5 - 6 in | Galvanized Steel |
| Flanged | | | |

Riser pipe

Pipe connections for WellPoint spear filter allowing flexibility in reaching different depth. Available in different material with/without 90° bends



| Length | Connections | | Material |
|----------------------|-------------|----------|---------------|
| 2 - 3 - 4 - 5 - 6 mm | 32 mm | 1 1/4 in | PVC/Aluminium |

Header pip with/without multiple cock assembly

Connected to multiple spear and riser pipes, acts as collector pipe for the complete WellPoint system. It is connected to pump via suction hoses.



| Length | Connections | | Material |
|----------------|--------------------|--------------|----------|
| 3 - 4 - 5,8 mm | 100 - 120 - 150 mm | 4 - 5 - 6 in | PE-HD |

Suction / discharge pipes and hoses

Available in different material, connection sizes and lengths gives excellent flexibility for you application.



| Connections | | Material |
|--|----------------------------|-------------------------------------|
| 40 - 50 - 100 - 120 - 150 - 200 - 250 - 300 mm | 4 - 5 - 6 - 8 - 10 - 12 in | PVC/PE HD/Galvanised Steel / Rubber |

For complete accessories range, refer the accessories booklet.

Product portfolio

GENERATORS

PORTABLE
1,6–12 kVA





MOBILE
9–1250* kVA



INDUSTRIAL
10–2250* kVA



LARGE POWER
800–1450 kVA



*Multiple configurations available to produce power for any size application

DEWATERING PUMPS

ELECTRIC SUBMERSIBLE
250–16.200 l/min



SURFACE PUMPS
833–23.300 l/min

ENERGY STORAGE SYSTEMS

ZENERGIZE



Diesel and electric options available

LIGHT TOWERS

DIESEL



BATTERY



ELECTRIC





PolyPump Ltd
Providing your pumping solutions
sales@polypump.co.uk
01296 488 294

AIR COMPRESSORS AND HANDHELD TOOLS

AIR COMPRESSORS
1–116 m³/min
7–345 bar



HANDHELD TOOLS
Pneumatic
Hydraulic
Petrol engine driven



ONLINE SOLUTIONS

SHOP ONLINE PARTS ONLINE
Spare parts for power equipment. We handle your orders 24 hours a day.



POWER CONNECT
Scan the QR code on your machine, and go to the QR Connect Portal to find all the information about your machine.



LIGHT THE POWER: YOUR SIZING TOOL
A useful calculator to help you choose the best solution for your power and light needs.

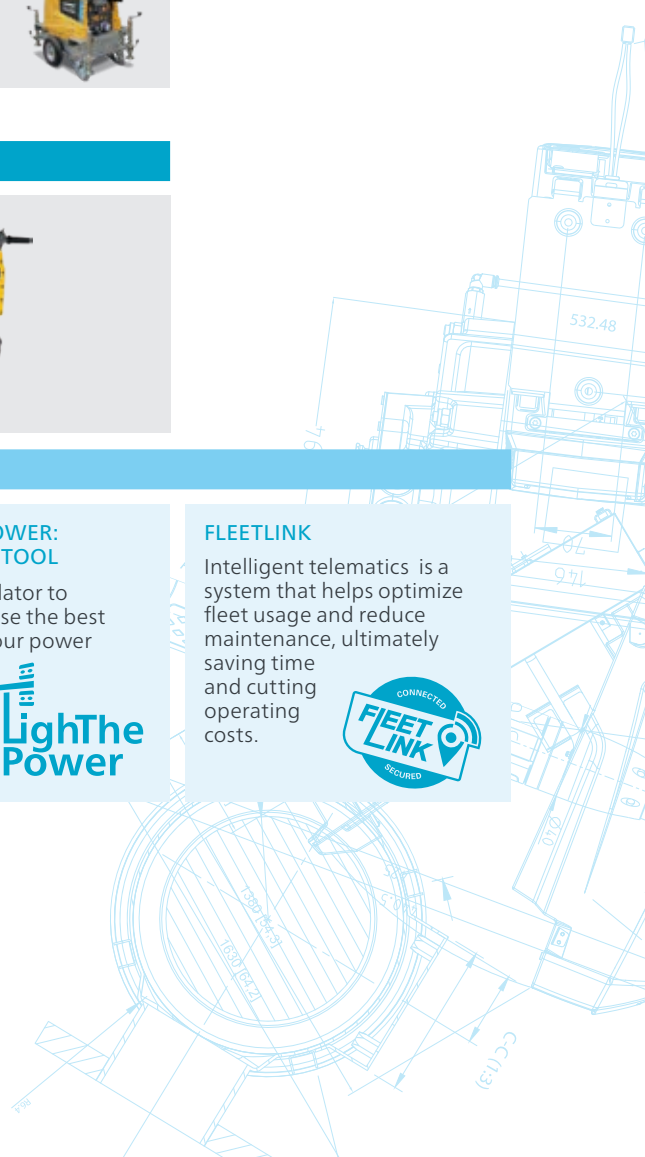

FLEETLINK
Intelligent telematics is a system that helps optimize fleet usage and reduce maintenance, ultimately saving time and cutting operating costs.

Atlas Copco Power Technique
www.atlascopco.com/ptba